

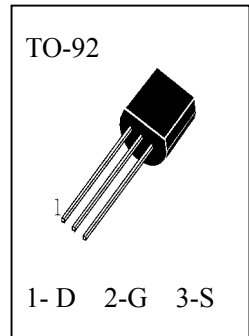

N-Channel Enhancement Mode Field Effect Transistor

General Description

These products have been designed to minimize on-state resistance while provide rugged, reliable, and fast switching performance. They can be used in most applications requiring up to 500mA DC. These products are particularly suited for low voltage, low current applications such as small servo motor control, power MOSFET gate drivers, and other switching applications.



Features

- High density cell design for low Rds(on).
- Voltage controlled small signal switch.
- Rugged and reliable.
- High saturation current capability.

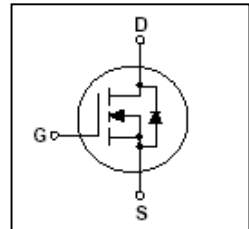

Maximum Ratings (Ta=25 unless otherwise specified)

T _{stg}	Storage Temperature	-----	-55~150
T _j	Operating Junction Temperature	-----	-55~150
V _{DSS}	Drain-Source Voltage	-----	60V
V _{DGR}	Drain-Gate Voltage (R _{GS} = 1M)	-----	60V
V _{GSS}	Gate-Source Voltage	-----	±20V
I _D	Drain Current (Continuous)	-----	500mA
P _D	Maximum Power Dissipation	-----	0.83W

Electrical Characteristics (Ta=25 unless otherwise specified)

Symbol	Items	Min.	Typ.	Max.	Unit	Conditions
BV _{DSS}	Drain-Source Breakdown Voltage	60			V	V _{GS} =0V, I _D =100uA
I _{DSS}	Zero Gate Voltage Drain Current			0.5	uA	V _{DS} =25V, V _{GS} =0V
I _{GSSF}	Gate – Body Leakage, Forward			10	nA	V _{GS} =15V, V _{DS} =0V
V _{GS(TH)}	Gate Threshold Voltage	0.8		3.0	V	V _{DS} = V _{GS} , I _D =1mA
R _{DS(ON)}	Static Drain-Source On-Resistance			5	Ω	V _{GS} =10V, I _D =200mA
g _{FS}	Forward Transconductance		320		mS	V _{DS} =10V, I _D =200mA
C _{iss}	Input Capacitance		24	40	pF	V _{DS} = 10 V, V _{GS} = 0 V, f = 1.0 MHz
C _{oss}	Output Capacitance		17	30	pF	
C _{rss}	Reverse Transfer Capacitance		7	10	pF	
ton	Turn - On Time			10	nS	V _{DD} = 25 V, I _D = 200 m A, V _{GS} = 10 V, R _{GEN} = 25 Ω
toff	Turn - Off Time			10	nS	



Performance Curves

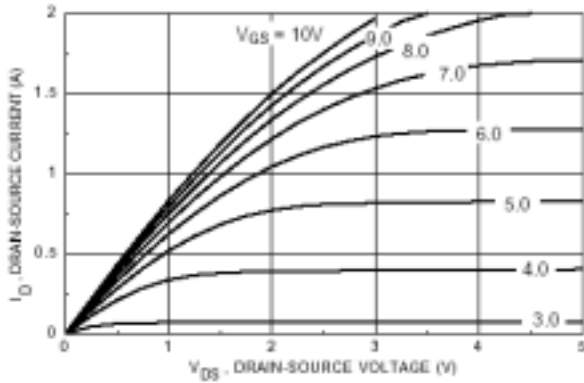

Figure 1. On-Region Characteristics.

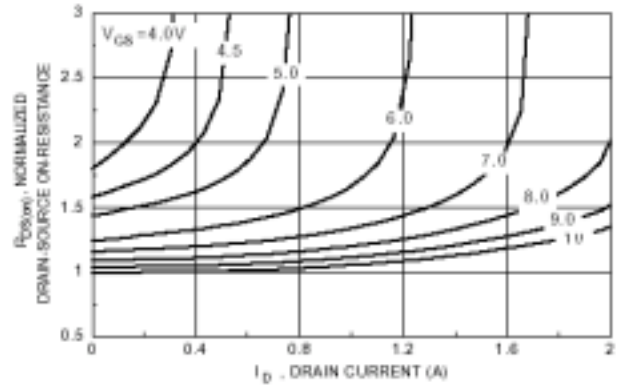

Figure 2. On-Resistance Variation with Gate Voltage and Drain Current.

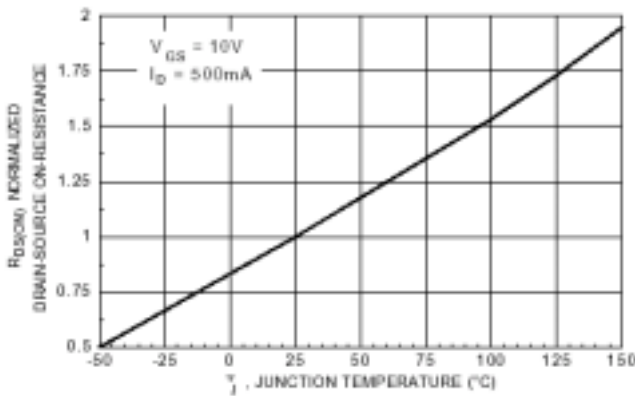

Figure 3. On-Resistance Variation with Temperature.

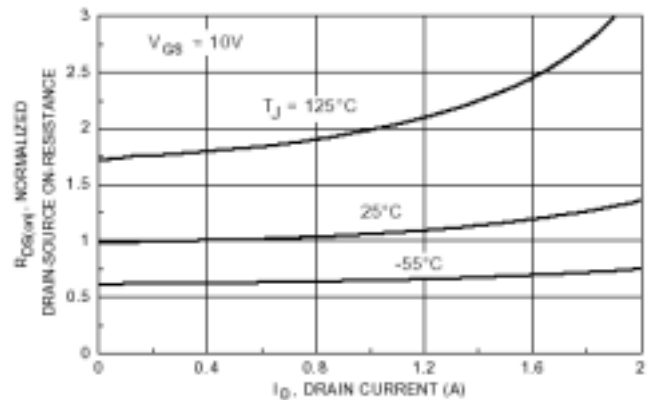

Figure 4. On-Resistance Variation with Drain Current and Temperature.

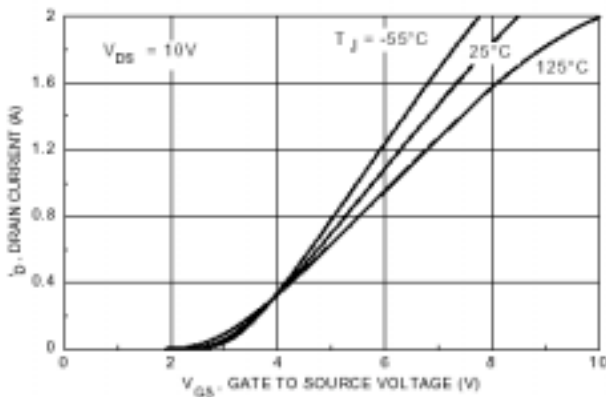

Figure 5. Transfer Characteristics.

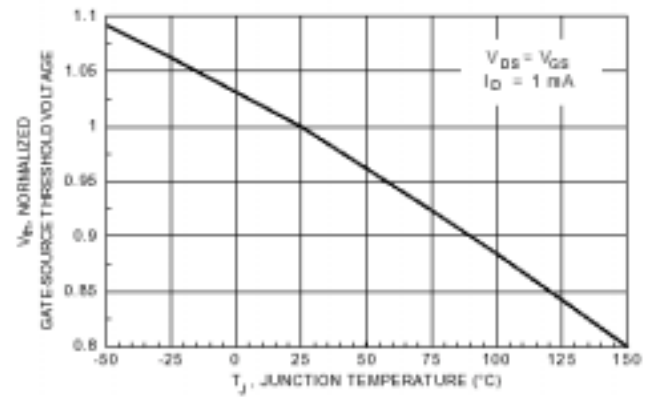

Figure 6. Gate Threshold Variation with Temperature.



Performance Curves

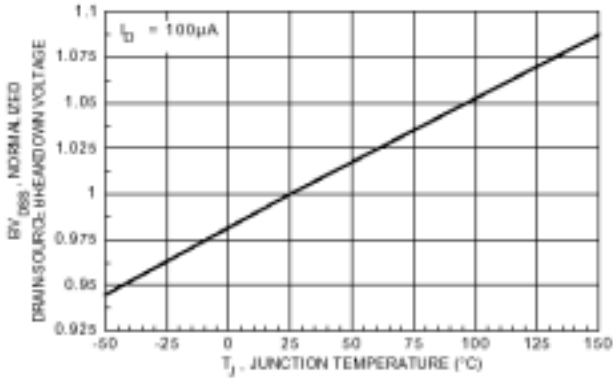

Figure 7. Breakdown Voltage Variation with Temperature.

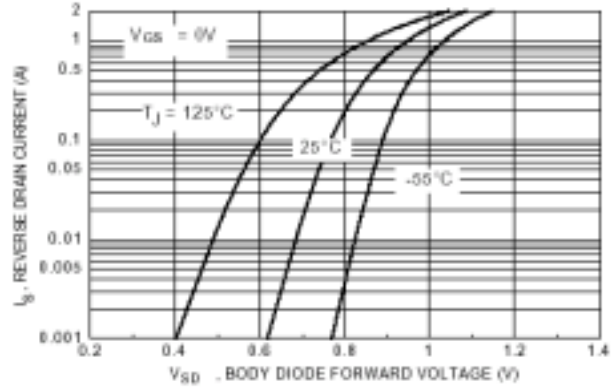

Figure 8. Body Diode Forward Voltage Variation with Current and Temperature.

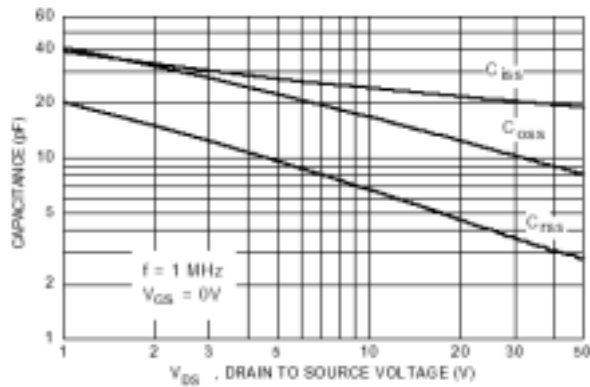

Figure 9. Capacitance Characteristics.

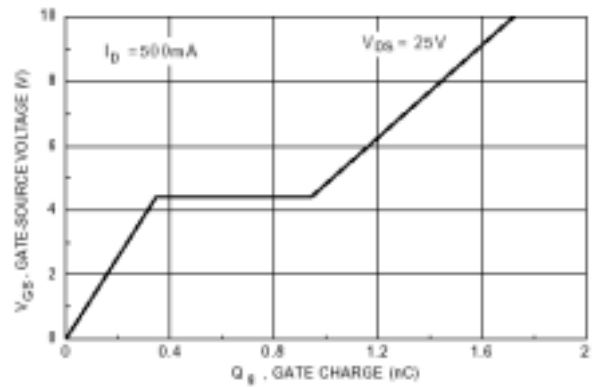

Figure 10. Gate Charge Characteristics.

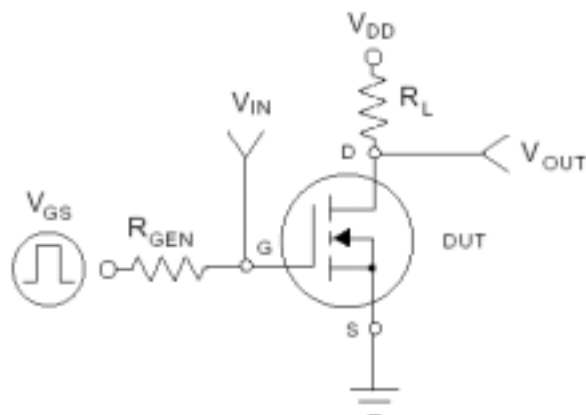

Figure 11. Switching Test Circuit.

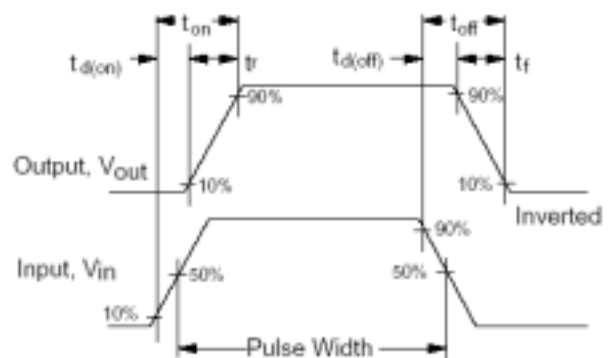

Figure 12. Switching Waveforms.



Performance Curves

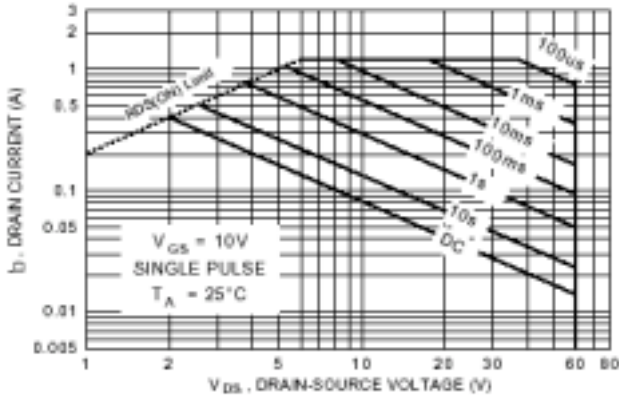

Figure 13. Maximum Safe Operating Area.

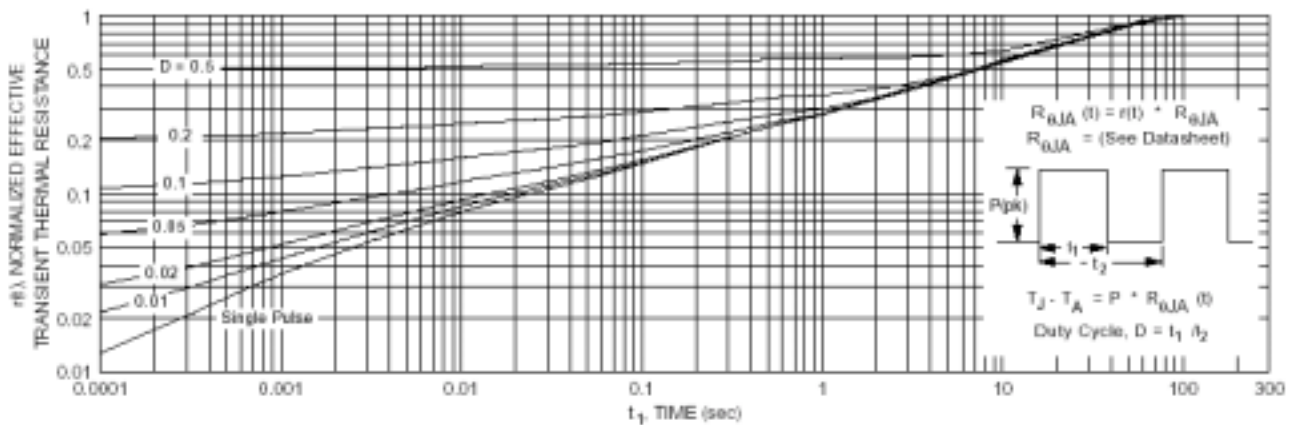

Figure 14. Transient Thermal Response Curve.